

HOW TO USE YOUR REFLECTOR TELESCOPE

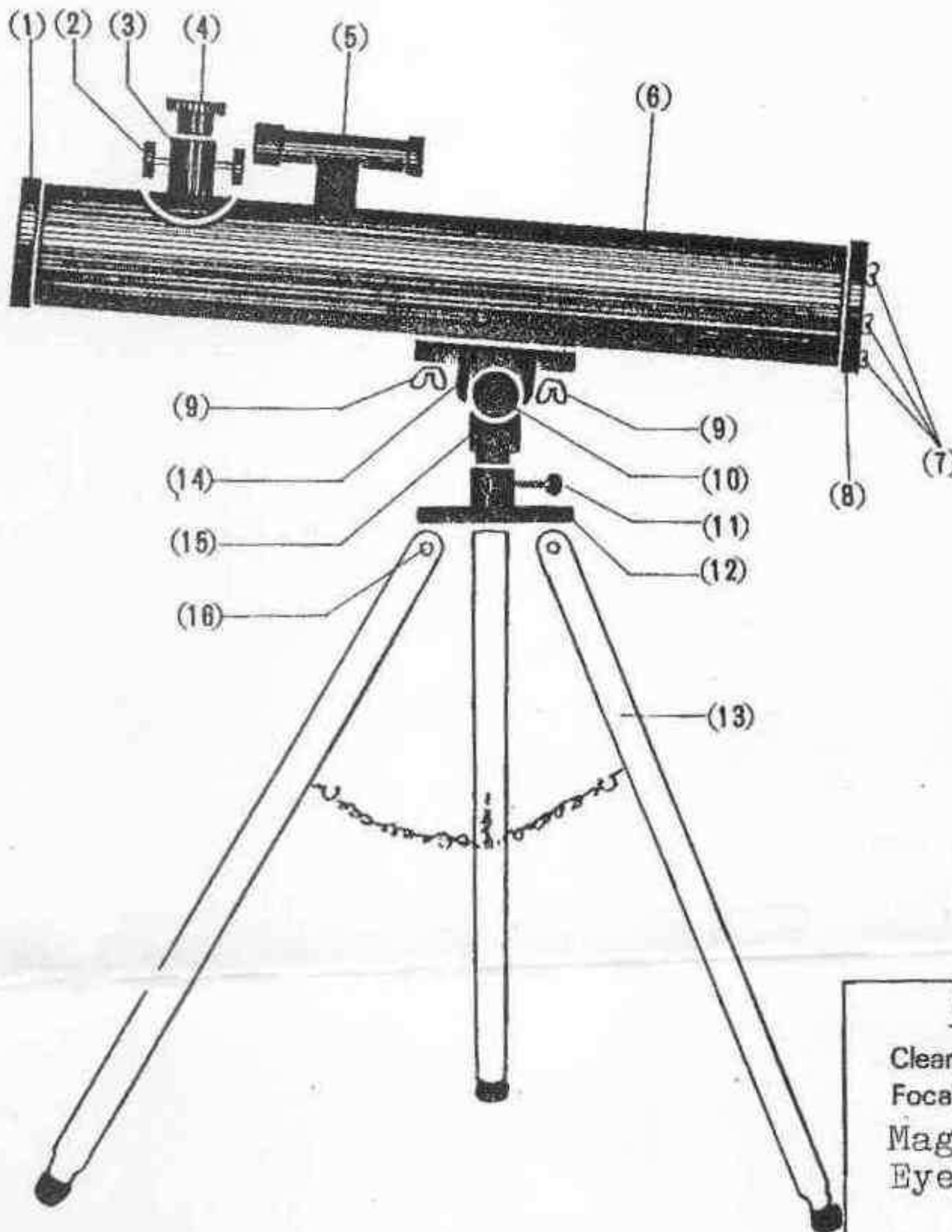

NAME OF PARTS :

1. Open Viewing End
2. Focusing Knob
3. Draw Tube
4. Eyepiece
5. 6X Finder Scope
6. Telescope Main Tube
7. Mirror Angle Adjustment
8. Closed End Cap
9. Mount Screw
10. Knob Bolt
11. Locking Bolt
12. Tripod Head
13. Wooden Floor Tripod
14. Mount
15. Connecting Piece
16. Bolt & Wing Nut

OPTICAL EFFECT :

Clear Aperture : 3"
 Focal Length : 700mm
 Magnifications:
 Eyepiece H8mm.....87X
 H20mm.....35X

INSTRUCTOIONS :

- 1) Take out Wooden Tripod (13) from the gift box, and set up Tripod Head (12) on the top of tripod with Bolts and Nuts (16).
- 2) Put Telescope tube (6) on the Mount (14) and fix tightly with Mount Screw (9). Now the telescope is ready for use.
- 3) Take off lens cap on Eyepiece (4).
- 4) While looking through eyepiece, adjust the telescope's angle to catch the object by Knob Bolt (10) and Locking Bolt (11), and tighten them when you caught the object.
- 5) At the same time, adjust the focusing tube by turning the Focusing Knob (2) even more slowly, back and forth, until the blurred image of the object is clearly seen.
- 6) Do not touch Mirror Angle Adjustment (7) as the optical axis is warped.
- 7) After the observation, store the telescope in a dry place, free from dust.
- 8) It is desired to set up your telescope in daylight hours in order to become completely familiar with its operation.
- 9) Do not view SUN through telescope or finder scope, as serious injury to eye may result.